



EXHAUST VALVE SPINDLE

DIE FORGING

FRICTION WELDING

SPECIAL WELDING



KSP

The best & reliable partner

KSP

KSP Has been pursuing the best quality through its own technology, customer's trust and specialization in Korea. Our ship engine valve spindle is manufactured with its state of the art infrastructure facility, special welding and professional manpower.

To keep this trend, KSP has been devoted to the development of its technology and quality production.

KSP is firmly carrying out its mission to meet all the requirements of customers through its ceaseless technology development and creative thinking.

So, as a result, KSP has successfully developed a large-sized and low-speed diesel engine valve by electrical upsetting preliminary molding process which is the first kind in the world.

Under its motto of the world's best optimum company, KSP will expand its technology scope to be the world's best engine valve maker.

Contents

- 02 Company Overview
- 04 History of company
- 05 Certified by the customers
- 06 Exhaust Valve Spindle for 2-Stroke Engine
- 08 Valve Spindle & Valve Seat Ring for 4-Stroke Engine
- 10 Die Forging
- 12 Friction Welding
- 14 Testing Equipments

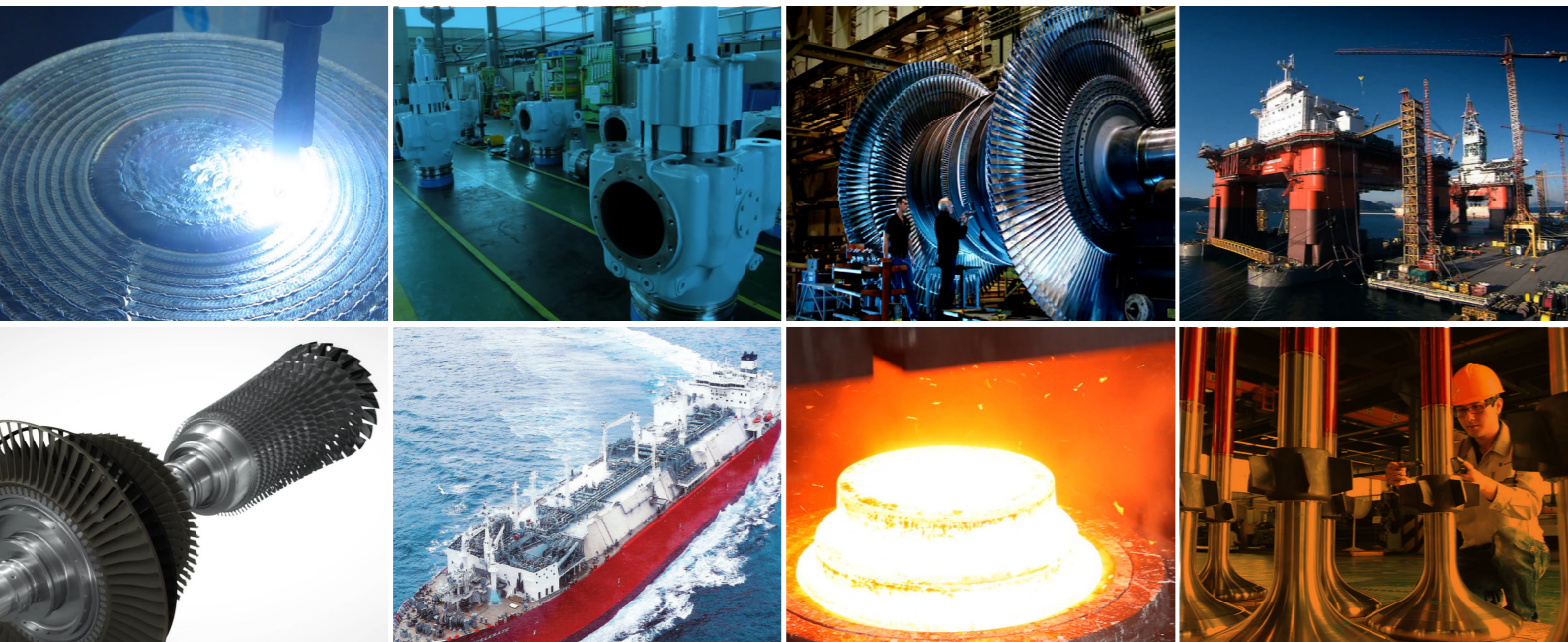

Certified by the Customers

KSP Co.,Ltd. understands the world's business needs therefore, vast choices of production items, excellent technology and top notch quality products are our priority commitments.

Our product confidence along with the eagerness to challenge the future are what inspire KSP Co.,Ltd. to become the best.



History

- 1991. 12** Established Korea Special Welding Co.
- 1998. 01** Supplied to Hyundai Heavy Industries Co., Ltd.
- 2000. 06** Changed company name to KSP Co., Ltd.
- 2002. 04** Established the KSP Metal Research Institute
- 2003. 03** Approved for the manufacture and supply of Forged Nimonic80A Exhaust Valve Spindle by the largest engine design maker in the world
- 2003. 04** Approved for the manufacture and supply of Forged Nimonic80A Exhaust Valve Spindle by WARTSILA Switzerland Ltd. Approved for the manufacture of Steel Forging by RINA and Lloyd's Register
- 2004. 07** Registered to KOSDAQ
- 2005. 12** Approved for the manufacture and supply of Forged Nimonic80A Exhaust Valve Spindle up to and including the size of 98MC
- 2006. 01** Registered the patent for manufacturing method of the economic valve spindle for two stroke diesel by flywheel friction welding
- 2006. 10** Preliminary approved for the manufacture and supply of Forged Nimonic80A Exhaust Valve Spindle up to and including the size of RTA96C
- 2007. 06** Developed and supplied Rotor Shaft to HHI
- 2010. 11** Approved all size Dura Spindle
- 2013. 01** Certificate of Approval (ISO 9001:2008, KS Q ISO 9001:2009, EN ISO 9001:2008)
- 2014. 01** Approved ISO14001:2004
- 2014. 07** Approved for Wartsila Valve Spindle PAW STL6 welding
- 2015. 04** Frequent inspected surveyor approved by Doosan
- 2016. 07** Approved for WinGD 2 stroke Valve Spindle
- 2017. 01** Approved for Exhaust Valve DuraSpindle including welding, rolling and age hardening of seat area for all engine sizes for MAN Energy Solutions two-stroke diesel engine (Renewal)
- 2017. 02** Approved for Rolled Nimonic80A Exhaust Valve Spindle for MAN Energy Solutions two-stroke diesel engines (Renewal)
- 2017. 02** Approved for Forged Nimonic 80A Exhaust Valve Spindle for MAN Energy Solutions two-stroke diesel engines (Renewal)
- 2018. 10** Agreement on Investment for M&A with Kumkang Kind Co., Ltd. consortium

Clients

A spirit of challenge and genuine entrepreneurship supported by our variety of products, excellent technologies and top most quality are our commitment to you. Our active businesses and aggressive management give us confidence in our products and are inspired by the need to push the limits of our future.

ENGINE PARTS	HHI/DOOSAN ENGINE/STX MAN Energy Solutions/Winterthur Gas & Diesel YMD/DMD/CMD/HHM/HITACHI/HANSHIN	FRICTION WELDING	HHI/STX/DONGSIN/EVERDIGM ROCK TOOLS HANDOK HYDRAULICS
FORGING	DOOSAN/VOLVO/HITACHI/MITSUBISHI CATERPILLAR/NABTESCO/HYUNDAI ROTEM	SPECIAL WELDING	DOOSAN HEAVY INDUSTRY/TOSHIBA UNION STEEL/PK VALVE



Exhaust Valve Spindle for 2-Stroke Engine

KSP has successfully developed the large-sized engine valve spindle to which Electrical Upsetting was applied for the first time in the world, and has been appointed "Venture Company" by Korean government.



MAN Energy Solutions



Winterthur Gas & Diesel



We create the highest quality using our specialized production management system and accumulated production know-how.

Main Products

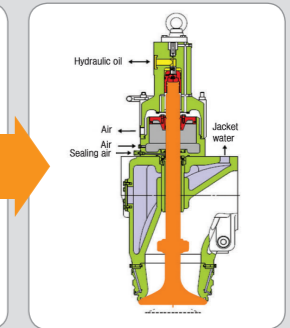
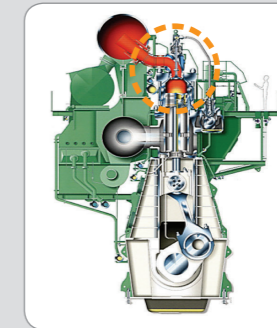
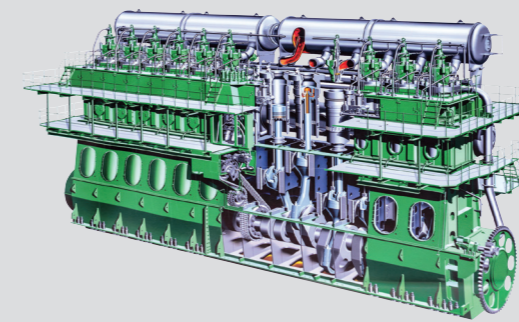

Products List

Classification	Engine Model
Nimonic80A Spindle	26MC ~ 98MC/E-C
Friction Welded Spindle	40MC-C ~ 98MC/E-C
DURA Spindle	35MC/E-C/B ~ 98MC/E-C

Classification	Engine Model
SNCrW Spindle	26MC ~ 70MC
Nimonic80A Spindle	WX35 ~ RT-flex96C
Friction Welded Spindle	RTA48T ~ RT-flex96C

Production Facilities



Electrical Upset Machine



7000ton Hydraulic Press



Welding Machine



CNC Horizontal Lathe

Production Process for Valve Spindle



Material



Upsetting



Die Forging



Heat-Treatment

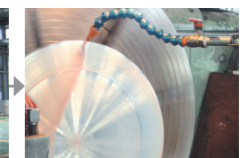

Lathe



CNC Turning



Vane Wheel

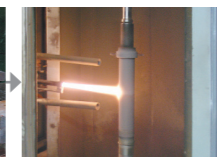

H.V.O.F Coating



Cleaning



Inspection

Valve Spindle & Valve Seat Ring for 4-Stroke Engine

High durability and high corrosion resistance even under high temperature and high pressure circumstance



HiMSEN



MAN Energy Solutions



Intake/Exhaust valve spindle and seat ring of diesel engine for ship generator.

Main Products

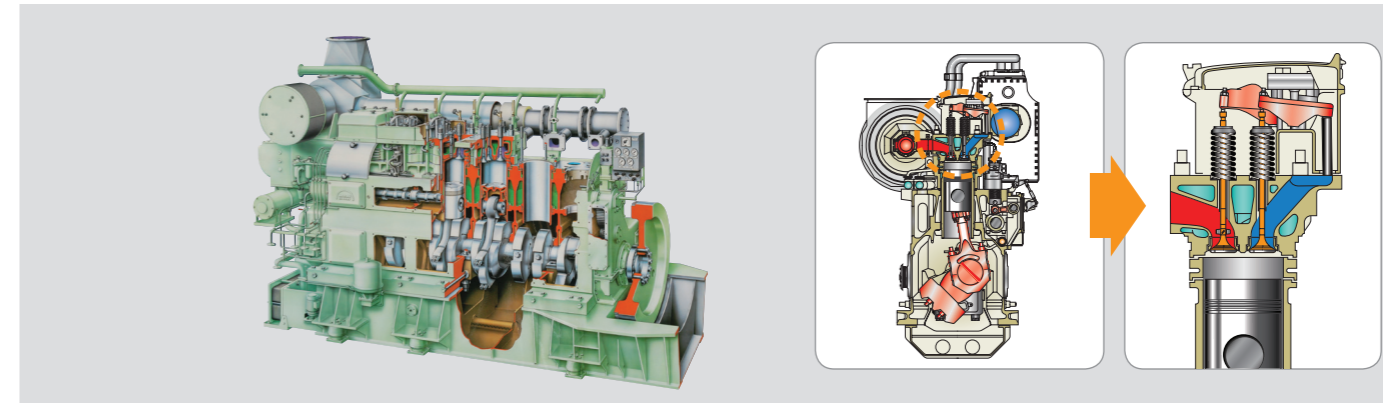

Products List

Engine Licensor	Description	Material	Engine Model
Hyundai Heavy Industries (HiMSEN)	Valve Spindle	Nimonic80A, SUH1, STR3	H16/24, H21/32, H25/33, H32/40, H46/60
	Valve Seat Ring	SCM440(H), G-X220CrMo33	
MAN Energy Solutions	Valve Spindle	Nimonic80A, X45CrSi9-3, SUH1, STR3	L16/24, L21/31, L23/30, L23/30H, L27/38, L28/32A, L28/32H, L32/40, LV32/40CD, 32/44, 35/44, 45/60, 48/60, 51/60, 58/64
	Valve Seat Ring	SCM440(H), G-X220CrMo33	
Hanshin Diesel Works	Valve Spindle	STR3, SUH35	LH26RG, LH28, LH28L, LH30.31L, LH34L
ETC	Valve Spindle	Nimonic80A, SUH1, STR3	6N18L.EN, 6N21L, N330, M200L DK20, POPPET, ETC
	Valve Seat Ring	SCM440(H)	

Production Facilities



Electrical Upset Machine

Hydraulic Press 1,400 ton

Mechanical Machining

Welding Machine

Production Process for Valve Spindle

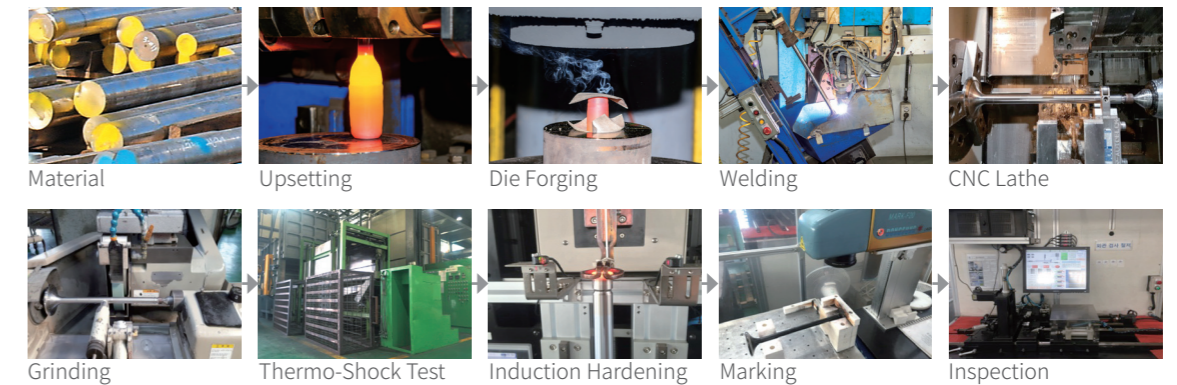

Material

Upsetting

Die Forging

Welding

CNC Lathe

Grinding

Thermo-Shock Test

Induction Hardening

Marking

Inspection

Die Forging

We are supplying various products for shipbuilding, industrial part, chemical plant. (Gear, Rod, Cylinder, Cover, Piston Crown, Flange, Etc)

Marine Engine

					
Connecting Rod	Rotor Shaft	Bottom Piece	Accumulator Shell	Accumulator Shell	Spur Gear
◦ Material : SCM 440 ◦ Weight (kg) : 240 ◦ Equipment : Ship Engine Part	◦ Material : SFCMV 1 ◦ Weight (kg) : 280 ◦ Equipment : Ship Engine Part	◦ Material : SCM 440 ◦ Weight (kg) : 284 ◦ Equipment : Ship Engine Part	◦ Material : SCM 440 ◦ Weight (kg) : 30 ◦ Equipment : Ship Engine Part	◦ Material : SCM 440 ◦ Weight (kg) : 60 ◦ Equipment : Ship Engine Part	◦ Material : 15CrNi6 ◦ Weight (kg) : 138 ◦ Equipment : Ship Engine Part

Construction Equipment

					
Idler	Hub-Sprocket	Ring Gear	Disk Ring	Head Cover	Cover End
◦ Material : 15B 35H ◦ Weight (kg) : 165 ◦ Equipment : Heavy Equipment	◦ Material : 1E 0361 ◦ Weight (kg) : 173 ◦ Equipment : Heavy Equipment	◦ Material : S45C ◦ Weight (kg) : 125 ◦ Equipment : Heavy Equipment	◦ Material : SKD 11 ◦ Weight (kg) : 50 ◦ Equipment : Heavy Equipment	◦ Material : S45C ◦ Weight (kg) : 118 ◦ Equipment : Heavy Equipment	◦ Material : S45C ◦ Weight (kg) : 165 ◦ Equipment : Heavy Equipment

Defense Industry

				
Sprocket	Idler Arm	Cylinder Block	Rim	Wheel Arm
◦ Material : AISI 4150 ◦ Weight (kg) : 75 ◦ Equipment : Tank	◦ Material : AISI 4150 ◦ Weight (kg) : 120 ◦ Equipment : Tank	◦ Material : SCM 440 ◦ Weight (kg) : 244 ◦ Equipment : Tank	◦ Material : A6061 ◦ Weight (kg) : 58 ◦ Equipment : Heavy Equipment	◦ Material : SNCM 439 ◦ Weight (kg) : 155 ◦ Equipment : Tank

Industrial Machinery

					
Pinion	Flange	Ball	Valve Body		
◦ Material : 17 CrNiMo 6 ◦ Weight (kg) : 104 ◦ Equipment : Wind Equipment	◦ Material : SF 440 ◦ Weight (kg) : 55 ◦ Equipment : Wind Equipment	◦ Material : A105 / LF2 / SUS316L ◦ Length : 333-493mm (13.1"-19.4") ◦ Thickness : 251-368mm (9.8"-14.5") ◦ Weight : 100-650kg	◦ Material : A105 / F11 / F22 / F91 / F92 ◦ Length : 350-814mm (13.7"-32") ◦ Thickness : 150-406mm (5.9"-16") ◦ Weight : 100-650kg	◦ Material : A105 / F11 / F22 / F91 / F92 ◦ Length : 350-814mm (13.7"-32") ◦ Thickness : 150-406mm (5.9"-16") ◦ Weight : 100-650kg	◦ Material : A105 / F11 / F22 / F91 / F92 ◦ Length : 350-814mm (13.7"-32") ◦ Thickness : 150-406mm (5.9"-16") ◦ Weight : 100-650kg

Die Forging products of KSP has the best quality due to the perfect manufacturing process. We have good reputation from both domestic and overseas customers in quality.

Production Facilities



Material Cutting-Band Saw



Heating-3ton/ch Heating Furnace

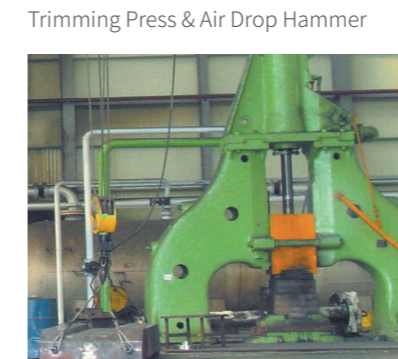

Trimming Press & Air Drop Hammer



Performing-3ton Air Drop Hammer



Forging-16ton Air Drop Hammer



Air Hammer



Trimming-1600ton Trimming Press

Forged Product (Piston Crown)

Main Facilities

Description	Capacity	Q'ty	Description	Capacity	Q'ty
Air Drop Hammer	16 ton	1	Trimming Press	1600 ton	1
Air Hammer	3 ton	1	Heating Furnace	6 ton / ch	3
Band Saw	-	8	Manipulator	4.5 ton	3

Ability of Die Forging

Circle Shape	Piston Crown, Idler, Valve Body, Disk Ring, Ring Gear etc.	Max. Outdia : Ø900mm Max. Thickness : 400mm, Max. Weight : 1000kg
Shaft	Con-Rod, Piston Rod, Front Axles, Cam Shaft, etc.	Max. Length : 2200mm, Max. Weight : 800kg





Material

Carbon Steel	ASTM A105, A181CL.60, 70, A266GR.1,2,3,4, A350LF.1,2, A765GR.1,2,4 / JIS S15C~S55C
Stainless Steel	ASTM A182F304(L), 316(L)
Alloy Steel	ASTM A182F11/F22/F51/F91/F92
Super Alloy Steel	Super 718, Nimonic80A
Nonferrous	Aluminium

Friction Welding

Premium quality and prolonged operating life through its high precision technology.

Main Products

				
Turbine Rotor ◦ Material : INCONELL+SCM440 ◦ Equipment : Ship Engine Part	Piston Rod (550ton) ◦ Material : S45C + S45C ◦ Equipment : Hydraulic	Rotor Shaft ◦ Material : SFCMV 1 ◦ Equipment : Ship Engine Part	Driver Shaft ◦ Material : SCM440 + SCM440 ◦ Equipment : Hydraulic	Drill ◦ Material : HSS + S45C ◦ Equipment : Drill

Production Facilities

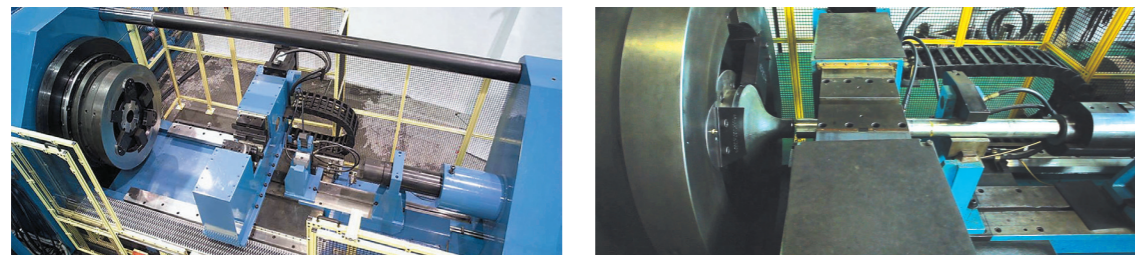

Business Showings

- Mechanic design for turbine and Rotor shaft in turbocharger (Hyundai Industry Co., Ltd.)
- Manufacture of hydraulic part and mechanical tool (YG-1 Co., Ltd.)

Model	Process Method	Capacity	Length(mm)
400	Hybrid	Ø60 - Ø250	3,000
100	Direct	Ø50 - Ø100	3,000
45	Direct	Ø20 - Ø75	1,000
30	Direct	Ø10 - Ø40	800

Special Welding

About Hardfacing-usage & applications

Hardfacing is one of the metal surface hardening buildup weldings to coat the surface of objects with metal, powder utilizing the plasma welding equipment named PTA(Plasma Transferred Arc).

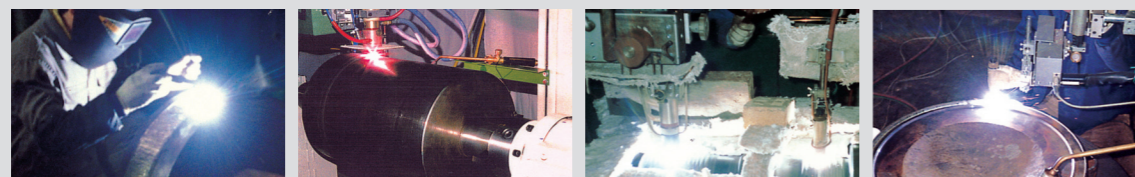

Repair Welding View

Axial Pump Sleeve

Power Plant Turbine Sleeve

Gate Disc

The Nimonic80A spindle has been used as the standard for two stroke engines, but the alternative version is that KSP has developed a new exhaust valve spindle that can give a substantial increase in the TBOs due to high metallic quality and hardness on seat with lower price.

Friction Welded Spindle



Production Process

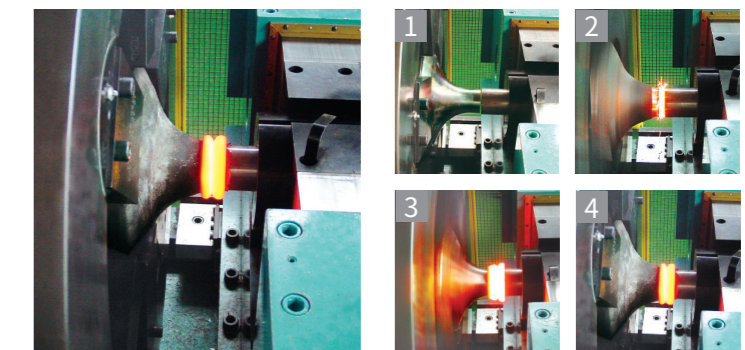

Comparison for Each types of Exhaust Valve Spindle

Classification	Original Technology by	Specification
Nimonic80A Spindle	MAN Energy Solutions Winterthur Gas & Diesel	Nimonic80A + HVOF / Cr
Friction Welded Spindle	KSP CO., LTD.	Nimonic 80A (Head part) + SNCrW (Stem part) + HVOF
DURA Spindle	MAN Diesel & Turbo	SNCrW + Inconell718 + (Inconell625) + HVOF

Strong Points of Friction Welded Spindle



- Better Quality on Seat Area
- Improve the mechanical property
- Decreased maintenance cost

Analysis of Friction Welding Process

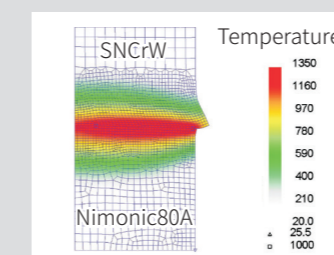

Deformation shape and temperature distribution after 1st force is applied (friction phase)

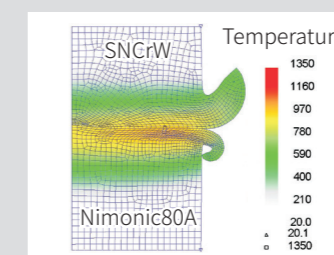

Deformation shape and temperature distribution after 2nd force is applied (upset phase)



Cross section of friction welded zone

Testing Equipments

Our quality products manufactured with the state-of-the-art production facilities are checked through perfect in-house inspection procedures dictated by our thorough quality warranty system. In order to ensure quality products, we are equipped with a perfect process-wise quality control system ranging from acceptance test of materials to shipment.



3D Coordinate Measuring Testing

Testing Equipments

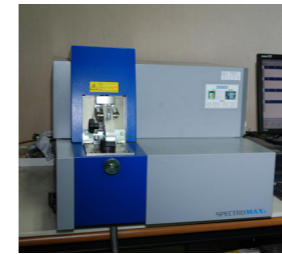

Chemical Ingredient Analysis



Universal Testing



Hardness Testing



Charpy Impact Testing



Microstructure Testing

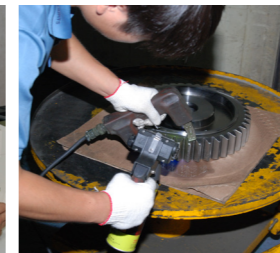

Magnetic Particle Testing



Liquid Penetrant Testing



Fatigue Testing

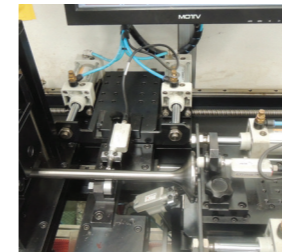

Automatic Linear Variable Differential Transformer Testing

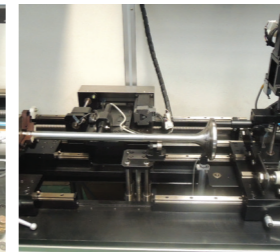

Automatic Eddy Current Testing



Checking of Dimensions

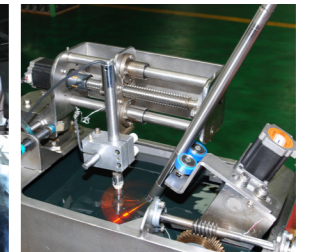

Automatic Ultrasonic Inspection Testing

KSP's another name is a place where **humanbeing's dream** comes true.

We, KSP professionally manufacture engine valves for vessel based on the high quality products.



www.kspvalve.com



1st. Factory

부산시 강서구 녹산산업북로 147 (송정동 1540-4)

TEL : (051) 831-6274~7 FAX : (051) 831-6273

E-mail : kspvalve@kspvalve.co.kr

(1540-4, Songjung-dong) 147, Noksansaneopbuk-ro,
Gangseo-gu, Busan, Korea.

TEL : +82-51-831-6274~7 FAX : +82-51-831-6273

2nd. Factory

부산시 강서구 녹산산단381로 86번길 43 (송정동 1658-6)

TEL : (051) 831-6270~2 FAX : (051) 831-6256

(1658-6, Songjung-dong) 43, Noksansandan 381-ro

86beon-gil, Gangseo-gu, Busan, Korea.

TEL : +82-51-831-6270~2 FAX : +82-51-831-6256

Specifications and features are subject to change without prior notice.

Copyright©2019 KSP All rights reserved 190408-01-EN Rev.01 April 8, 2019